

FIG. 1

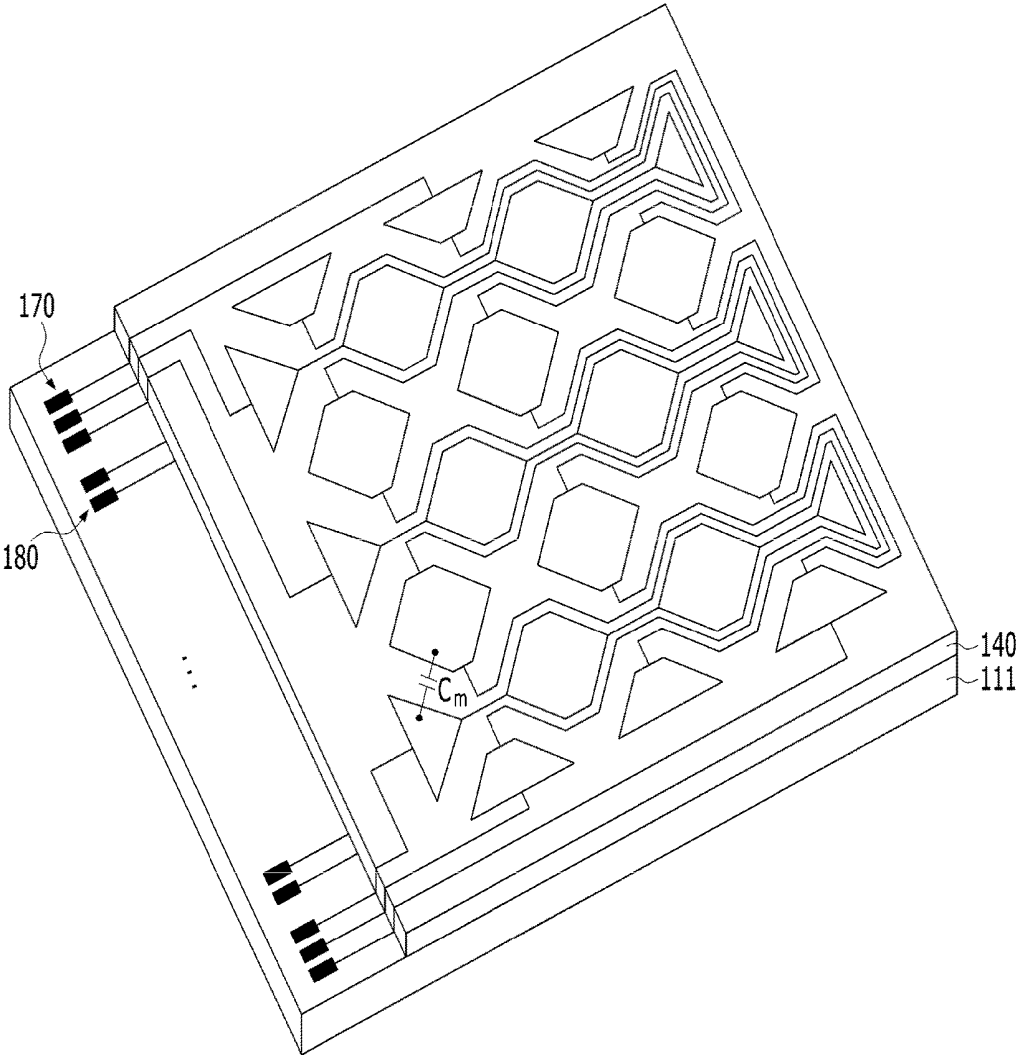

FIG. 2

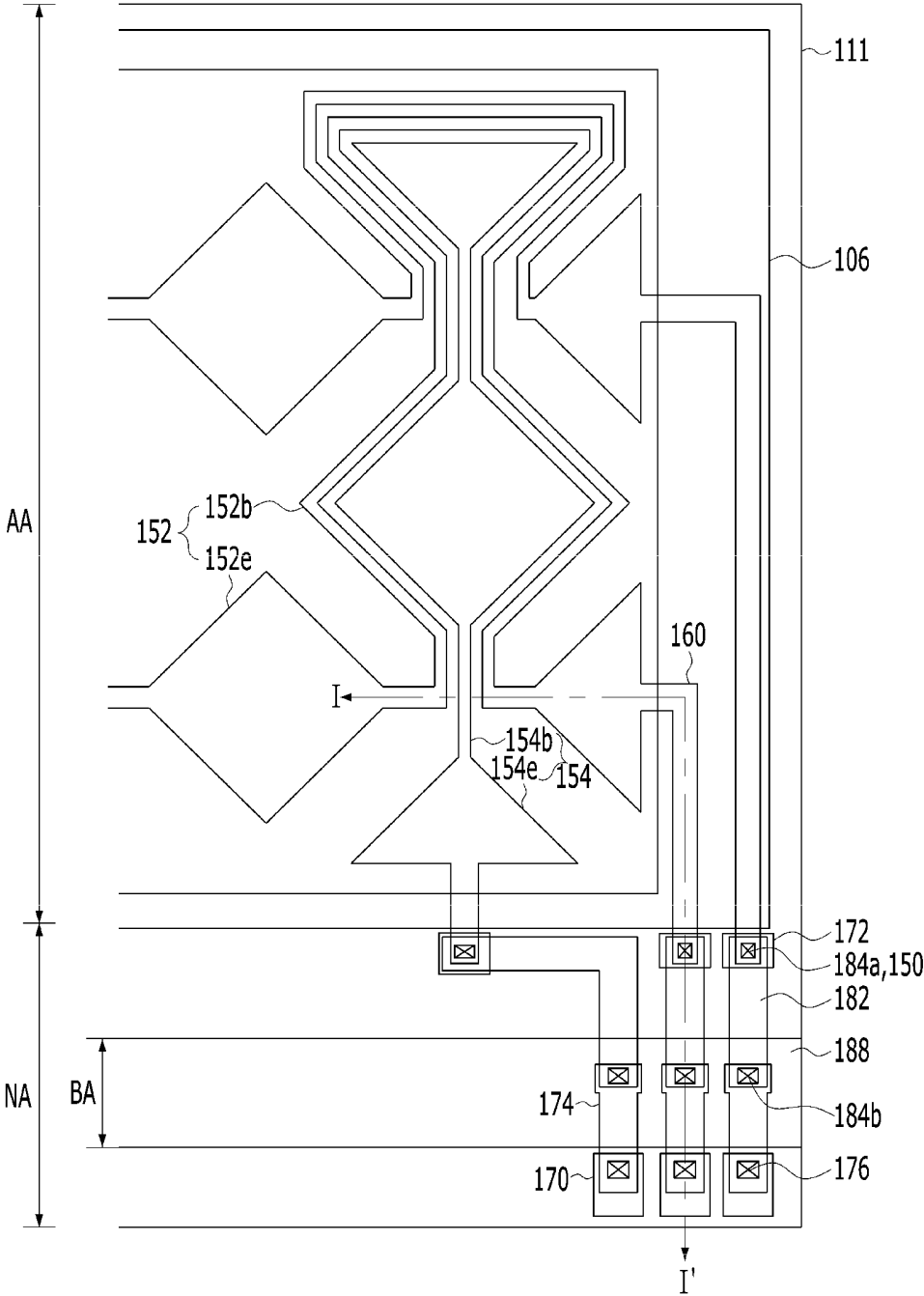

FIG. 3

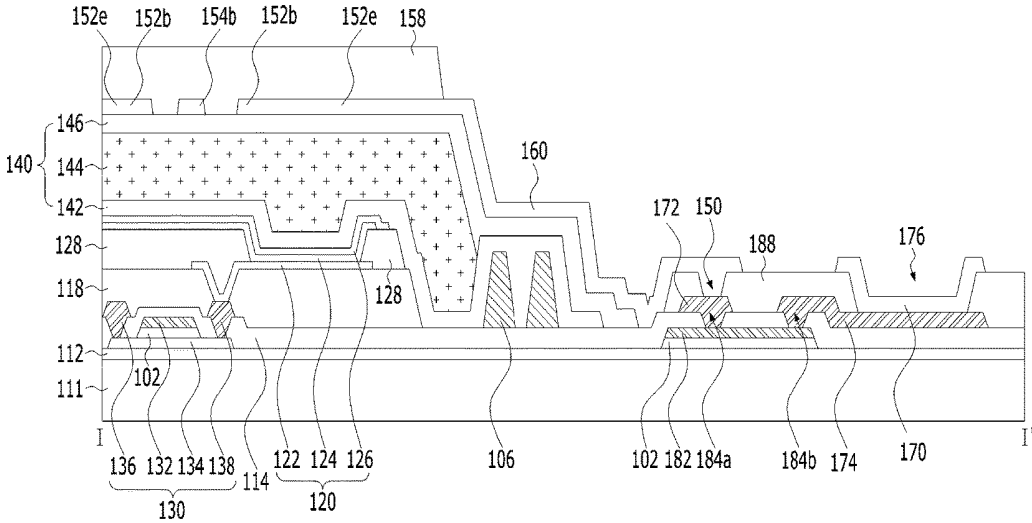

FIG. 4

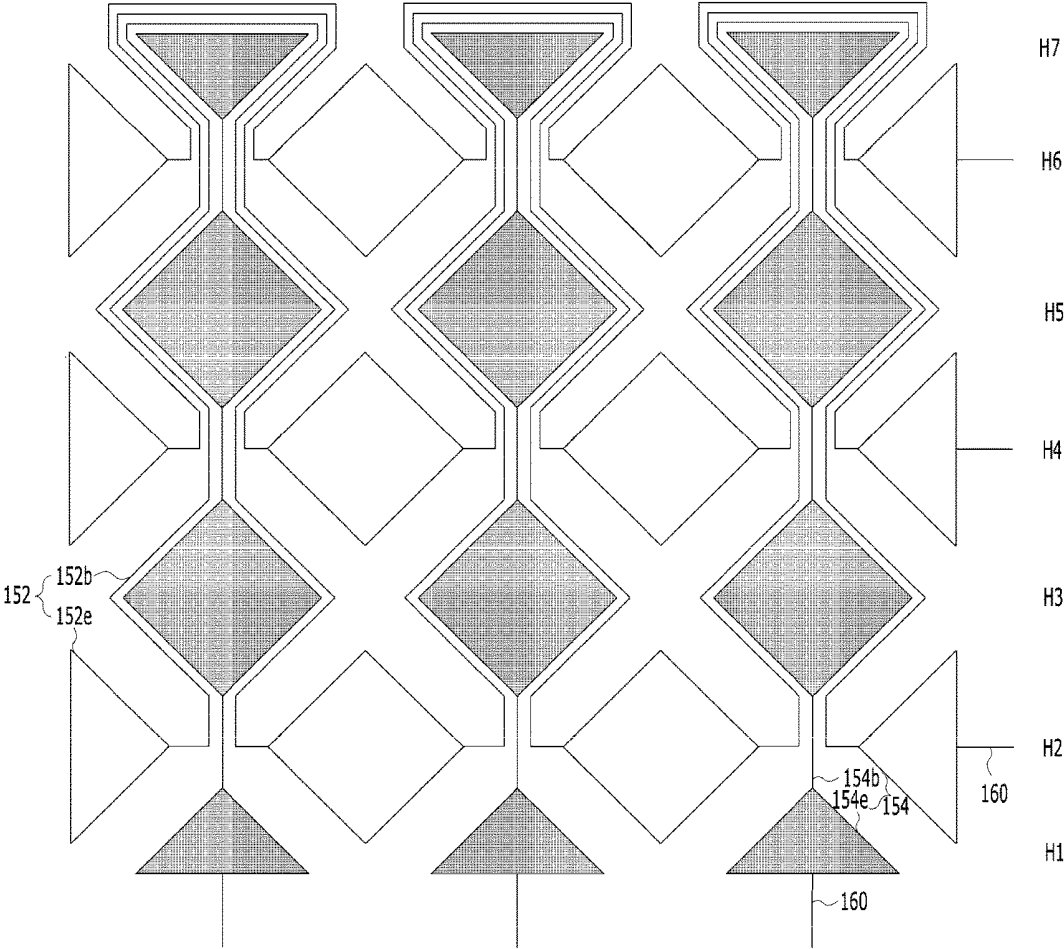

FIG. 5

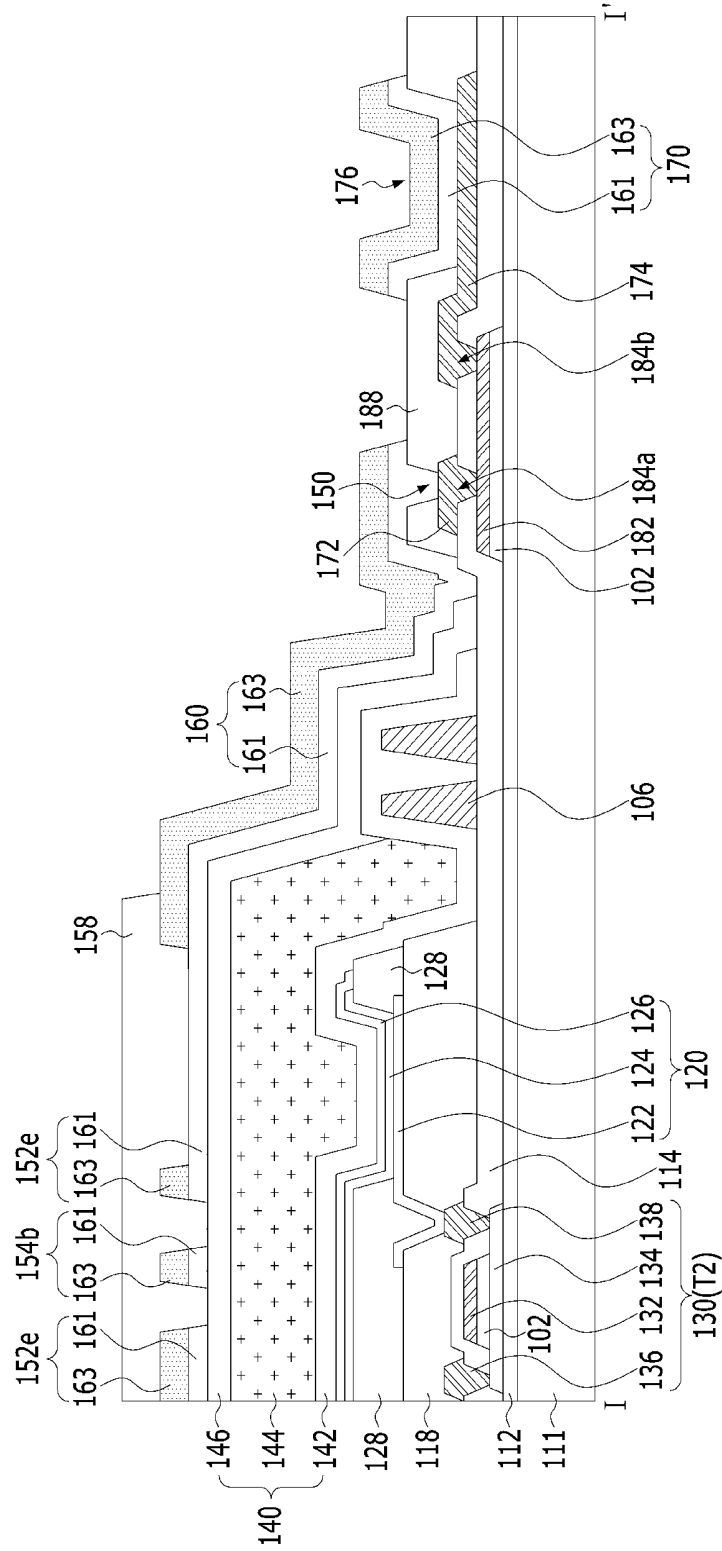

FIG. 6

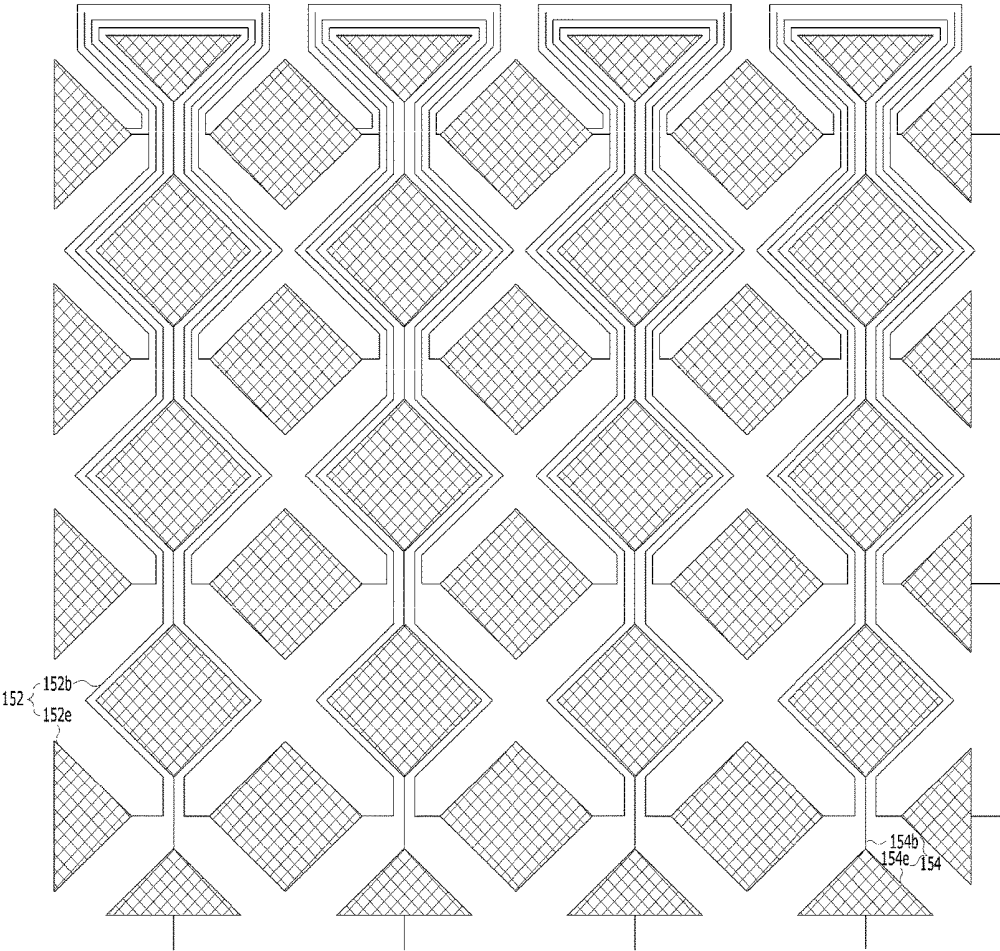

FIG. 7A

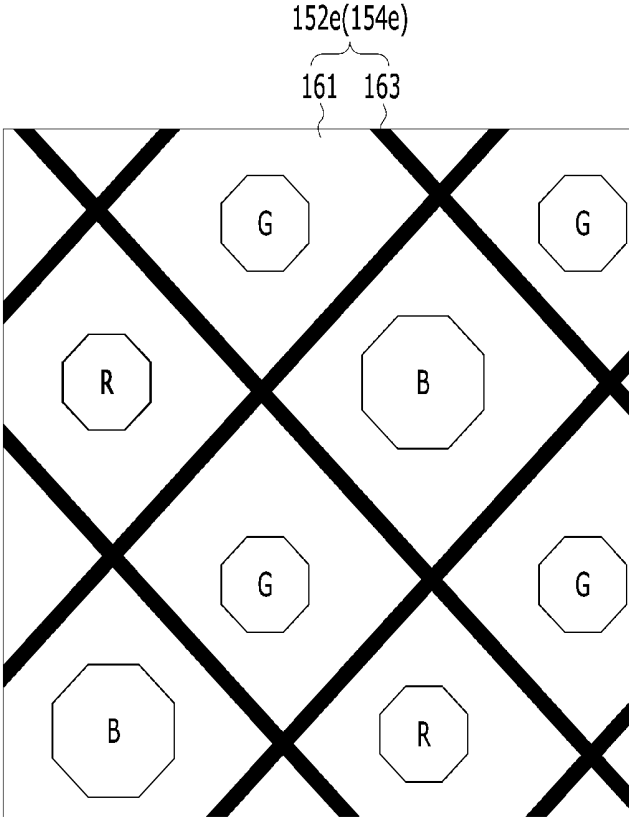

FIG. 7B

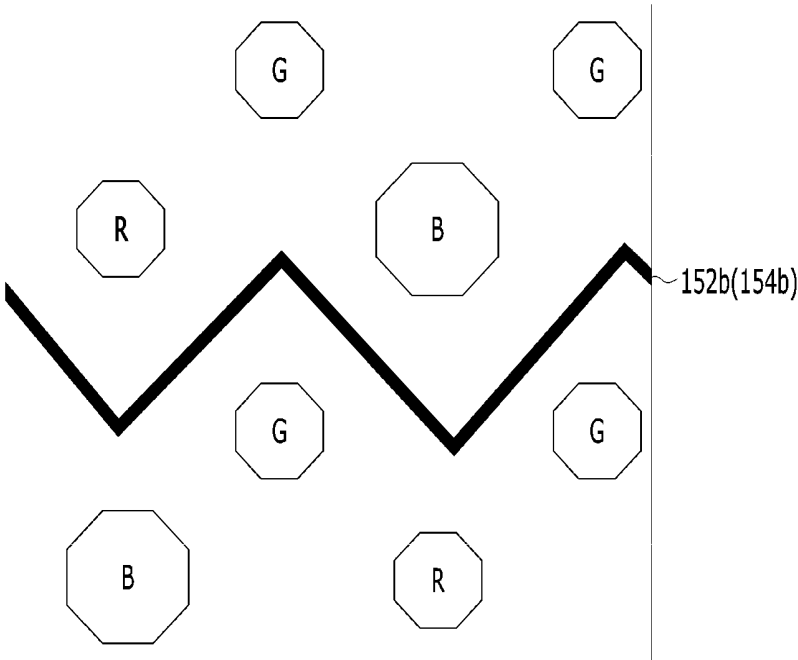

FIG. 8

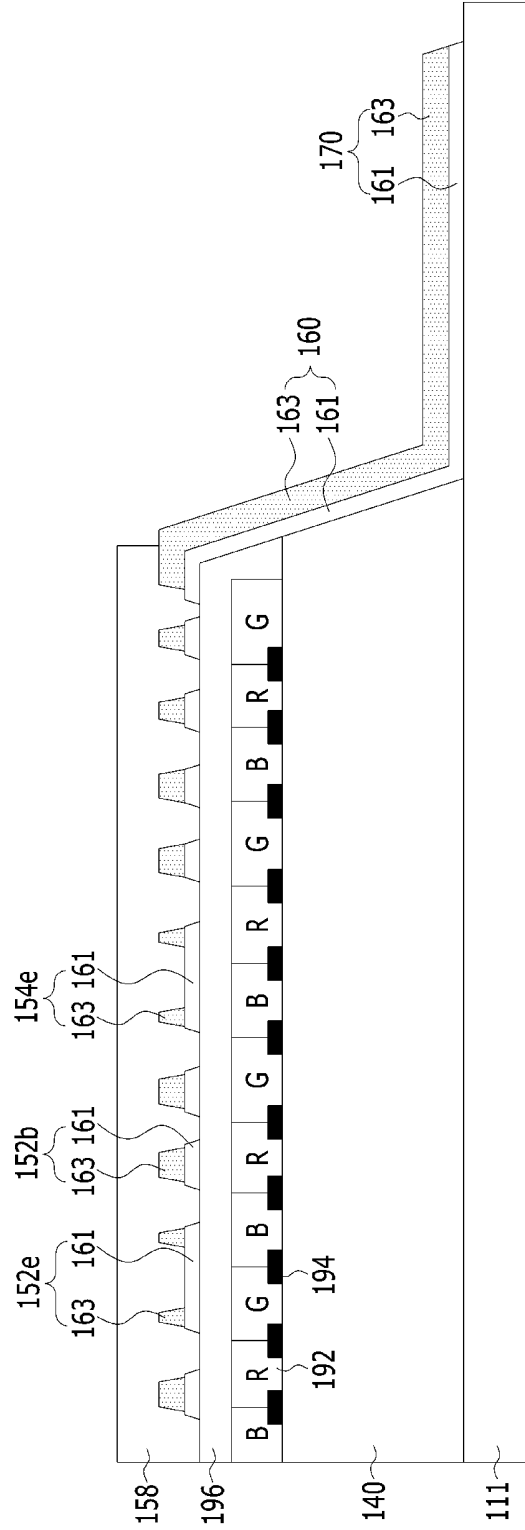

FIG. 9

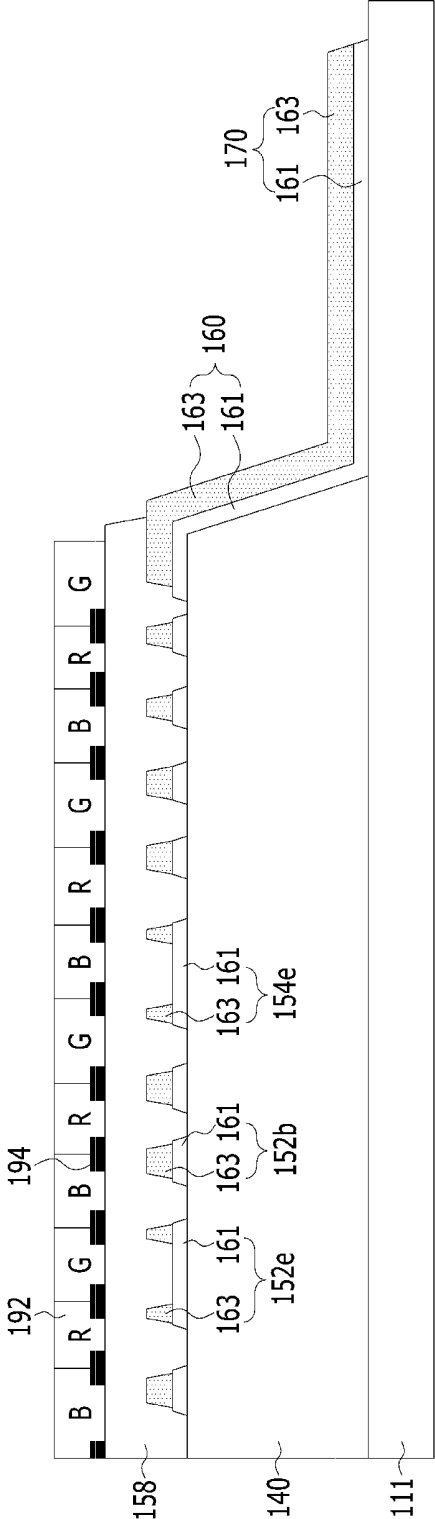

FIG. 10

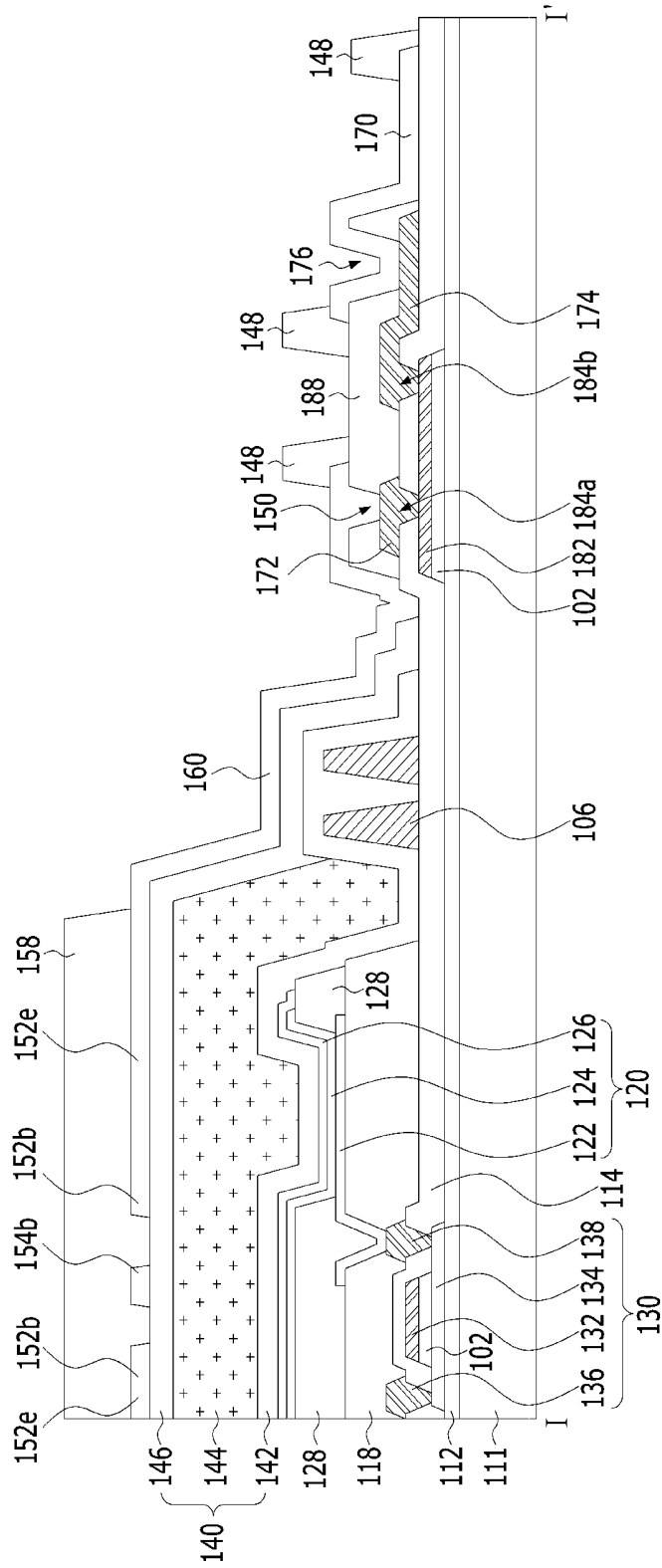

FIG. 11

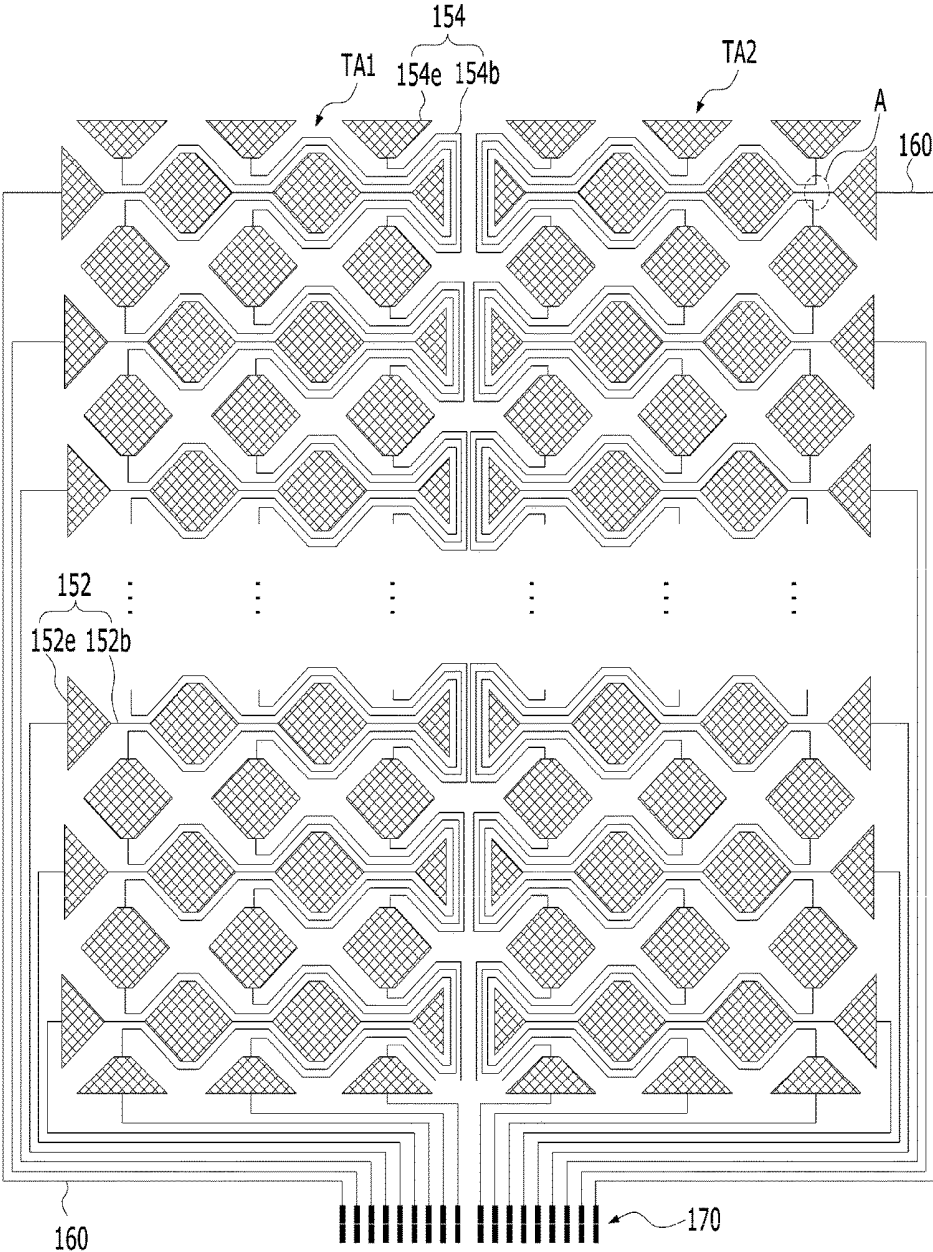

FIG. 12A

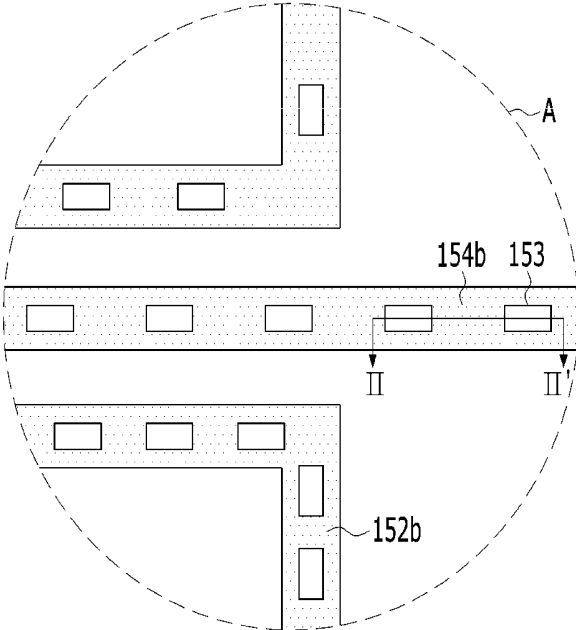

FIG. 12B

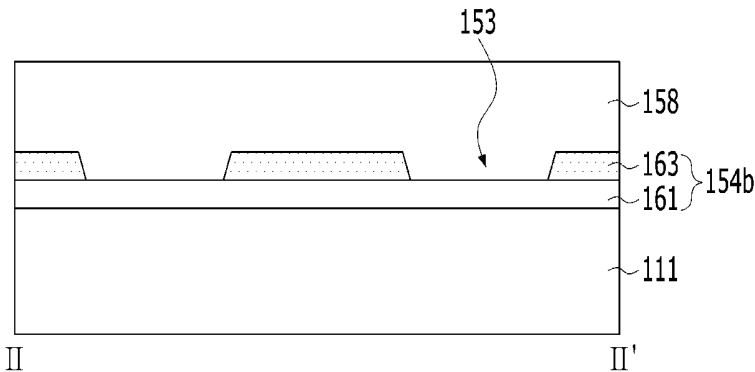

FIG. 12C

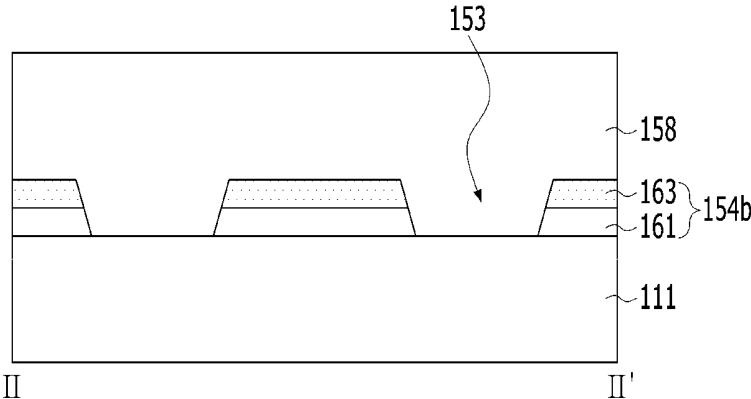
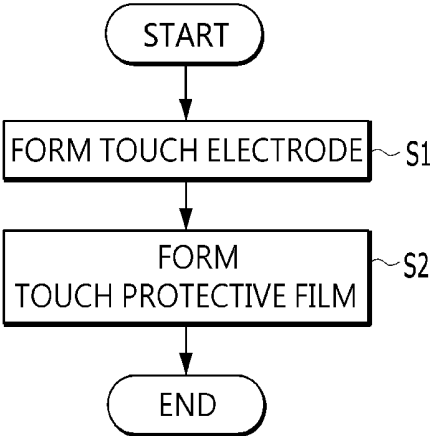

FIG. 13



ORGANIC LIGHT-EMITTING DISPLAY DEVICE HAVING TOUCH SENSOR

CROSS-REFERENCE TO RELATED APPLICATION

[0001] This application claims the priority benefit of Korean Patent Application No. 10-2018-0044949, filed on Apr. 18, 2018, which is hereby incorporated by reference as if fully set forth herein.

BACKGROUND OF THE INVENTION

Field of the Invention

[0002] The present invention relates to a display device, and more particularly to an organic light-emitting display device having a touch sensor that can achieve structural simplification and cost reduction.

Discussion of the Related Art

[0003] A touchscreen is an input device through which a user can input a command by selecting instructions displayed on a screen of a display device using a hand or an object. To accomplish this, the touchscreen converts a contact position that directly contacts a human hand or an object into an electrical signal and receives selected instructions from the contact position as an input signal. Such a touchscreen can substitute for a separate input device that is connected to a display device and operated, such as a keyboard or a mouse, and thus the range of application of the touchscreen has gradually increased.

[0004] In general, a touchscreen is attached to the front surface of a display panel, such as a liquid crystal display panel or an organic electroluminescent display panel, using an adhesive. In this case, since the touchscreen is separately manufactured and then attached to the front surface of the display panel, an additional attachment process is carried out, and thus the overall process becomes complicated and manufacturing costs are increased.

SUMMARY OF THE INVENTION

[0005] Accordingly, the present invention is directed to an organic light-emitting display device having a touch sensor that substantially obviates one or more problems due to limitations and disadvantages of the related art.

[0006] An object of the present invention is to provide an organic light-emitting display device having a touch sensor that can achieve structural simplification and cost reduction.

[0007] Additional advantages, objects, and features of the invention will be set forth in part in the description which follows and in part will become apparent to those having ordinary skill in the art upon examination of the following or can be learned from practice of the invention. The objectives and other advantages of the invention can be realized and attained by the structure particularly pointed out in the written description and claims hereof as well as the appended drawings.

[0008] To achieve these objects and other advantages and in accordance with the purpose of the invention, as embodied and broadly described herein, an organic light-emitting display device includes a touch sensor formed in a single-layer structure and disposed on an encapsulation unit disposed on a light-emitting element, wherein first and second bridges and first and second touch electrodes included in the

touch sensor having a single-layer structure are formed of the same material as each other in the same plane, the first and second bridges and the first and second touch electrodes being disposed on the uppermost layer of the encapsulation unit, thereby simplifying the structure thereof and reducing costs.

[0009] It is to be understood that both the foregoing general description and the following detailed description of the present invention are exemplary and explanatory and are intended to provide further explanation of the invention as claimed.

BRIEF DESCRIPTION OF THE DRAWINGS

[0010] The accompanying drawings, which are included to provide a further understanding of the invention and are incorporated in and constitute a part of this application, illustrate embodiment(s) of the invention and together with the description serve to explain the principle of the invention. In the drawings:

[0011] FIG. 1 is a perspective view showing an organic light-emitting display device having a touch sensor according to a first embodiment of the present invention;

[0012] FIG. 2 is a plan view showing the organic light-emitting display device having the touch sensor shown in FIG. 1;

[0013] FIG. 3 is a cross-sectional view taken along line I-I' in FIG. 2;

[0014] FIG. 4 is a plan view showing the first bridge extending in a convoluted form shown in FIG. 2 in detail;

[0015] FIG. 5 is a cross-sectional view showing an organic light-emitting display device having a touch sensor according to a second embodiment of the present invention;

[0016] FIG. 6 is a plan view showing the first and second touch electrodes shown in FIG. 5;

[0017] FIG. 7A is a plan view showing the first and second touch electrodes including opaque conductive films shown in FIG. 6 in detail, and FIG. 7B is a plan view showing the first and second bridges shown in FIG. 6 in detail;

[0018] FIG. 8 is a cross-sectional view showing an organic light-emitting display device having a touch sensor according to a third embodiment of the present invention;

[0019] FIG. 9 is a cross-sectional view showing another example of the color filter array shown in FIG. 8;

[0020] FIG. 10 is a cross-sectional view showing an organic light-emitting display device having a touch sensor according to a fourth embodiment of the present invention;

[0021] FIG. 11 is a plan view showing the organic light-emitting display device having the touch sensor according to the embodiment(s) of the present invention that is applied to a large-area product;

[0022] FIG. 12A is a plan view showing region A of FIG. 11 in detail, and FIGS. 12B and 12C are cross-sectional views taken along line II-II' in FIG. 12A; and

[0023] FIG. 13 is a flowchart showing a method of manufacturing an organic light-emitting display device having a touch sensor according to one or more embodiments of the present invention.

DETAILED DESCRIPTION OF THE EMBODIMENTS

[0024] Reference will now be made in detail to exemplary embodiments of the present invention, examples of which are illustrated in the accompanying drawings. Wherever

possible, the same reference numbers will be used throughout the drawings to refer to the same or like parts.

[0025] FIG. 1 is a perspective view showing an organic light-emitting display device having a touch sensor according to the present invention. FIG. 2 is a plan view showing the organic light-emitting display device having the touch sensor shown in FIG. 1. FIG. 3 is a cross-sectional view taken along line I-I' in FIG. 2, and FIG. 4 is a plan view showing the first bridge extending in a convoluted form shown in FIG. 2 in detail. All the components of the organic light-emitting display device having the touch sensor according to all embodiments and examples of the present invention are operatively coupled and configured.

[0026] The organic light-emitting display device having a touch sensor shown in FIG. 1 includes a plurality of sub-pixels arranged in a matrix form on a substrate 111, an encapsulation unit 140 disposed on the sub-pixels, and a mutual capacitance C_m disposed on the encapsulation unit 140.

[0027] The organic light-emitting display device having a touch sensor has, as shown in FIG. 2, an active area AA disposed on the substrate 111 and a non-active area NA disposed adjacent to the active area AA. The substrate 111 is formed of a flexible material such as plastic or glass so as to be bendable. For example, the substrate is formed of polyimide (PI), polyethylene terephthalate (PET), polyethylene naphthalate (PEN), polycarbonate (PC), polyethersulfone (PES), polyacrylate (PAR), polysulfone (PSF), or cycloolefin copolymer (COC).

[0028] The active area AA displays an image through unit pixels arranged in a matrix form. Each unit pixel includes red, green and blue sub-pixels, or includes red, green, blue, and white sub-pixels, but it is possible to have different combinations.

[0029] Each of the sub-pixels includes, as shown in FIG. 3, a pixel-driving circuit including a driving thin-film transistor 130, and a light-emitting element 120 connected to the pixel-driving circuit.

[0030] The driving thin-film transistor 130 controls current supplied from a high-voltage supply line to the light-emitting element 120 in response to a data signal supplied to a gate electrode of the driving thin-film transistor 130, thus adjusting the amount of light emitted from the light-emitting element 120.

[0031] Such a driving thin-film transistor 130 includes a semiconductor layer 134 disposed on a buffer layer 112, a gate electrode 132 overlapping the semiconductor layer 134 with a gate insulating film 102 interposed therebetween, and source and drain electrodes 136 and 138 formed on an interlayer insulating film 114 and contacting the semiconductor layer 134. Here, the semiconductor layer 134 is formed of at least one of an amorphous semiconductor material, a polycrystalline semiconductor material, or an oxide semiconductor material.

[0032] The light-emitting element 120 includes an anode 122, at least one light-emitting stack 124 formed on the anode 122, and a cathode 126 formed on the light-emitting stack 124.

[0033] The anode 122 is electrically connected to the drain electrode 138 of the driving thin-film transistor 130, which is exposed through a pixel contact hole penetrating a pixel planarization layer 118. An inorganic protective layer as well as the pixel planarization layer 118 can be disposed between the anode 122 and a driving transistor T2.

[0034] The at least one light-emitting stack 124 is formed on the anode 122 in the emission area provided by a bank 128. The light-emitting stack 124 is formed by stacking, on the anode 122, a hole-related layer, an organic light-emitting layer, and an electron-related layer, either in this order or in the reverse order. In addition, the light-emitting stack 124 can include first and second light-emitting stacks, which face each other with a charge generation layer interposed therebetween. In this case, an organic light-emitting layer of any one of the first and second light-emitting stacks generates blue light, and an organic light-emitting layer of the remaining one of the first and second light-emitting stacks generates yellow-green light, with the result that white light is generated via the first and second light-emitting emitting stacks. The white light generated from the light-emitting stack 124 is incident on a color filter disposed on or under the light-emitting stack 124, thus generating a color image. Alternatively, it is possible to generate a color image in a manner such that each light-emitting stack 124 generates colored light corresponding to each sub-pixel without a separate color filter. That is, a light-emitting stack 124 of a red sub-pixel can generate red light, a light-emitting stack 124 of a green sub-pixel can generate green light, and a light-emitting stack 124 of a blue sub-pixel can generate blue light.

[0035] The cathode 126 is formed so as to face the anode 122 with the light-emitting stack 124 interposed therebetween and is connected to a low-voltage supply line.

[0036] The encapsulation unit 140 prevents external moisture or oxygen from entering the light-emitting element 120, which is vulnerable to external moisture or oxygen. To this end, the encapsulation unit 140 includes at least one inorganic encapsulation layer 142 and at least one organic encapsulation layer 144. In the present invention, the structure of the encapsulation unit 140 in which a first inorganic encapsulation layer 142, an organic encapsulation layer 144 and a second inorganic encapsulation layer 146 are sequentially stacked will be described by way of example.

[0037] The first inorganic encapsulation layer 142 is formed on the substrate 111, on which the cathode 126 has been formed. The second inorganic encapsulation layer 146 is formed on the substrate 111, on which the organic encapsulation layer 144 has been formed, and covers the upper surface, the lower surface and the lateral surfaces of the organic encapsulation layer 144 together with the first inorganic encapsulation layer 142.

[0038] The first and second inorganic encapsulation layers 142 and 146 minimize or prevent permeation of external moisture or oxygen into the light-emitting stack 124. The first and second inorganic encapsulation layers 142 and 146 are formed of an inorganic insulating material, which can be deposited at a low temperature, such as silicon nitride (SiN_x), silicon oxide (SiO_x), silicon oxide nitride (SiON), or aluminum oxide (Al₂O₃). Accordingly, the first and second inorganic encapsulation layers 142 and 146 are deposited in a low-temperature atmosphere, thereby preventing damage to the light-emitting stack 124, which is vulnerable to a high-temperature atmosphere, during a process of depositing the first and second inorganic encapsulation layers 142 and 146.

[0039] The organic encapsulation layer 144 serves as a buffer to dampen stress between respective layers according to bending of the organic light-emitting display device and enhances the planarization performance of the organic light-

emitting display device. The organic encapsulation layer **144** is formed on the substrate **111**, on which the first inorganic encapsulation layer **142** has been formed, using a non-photosensitive organic insulating material, such as PCL, acrylic resin, epoxy resin, polyimide, polyethylene or silicon oxycarbide (SiOC), or using a photosensitive organic insulating material such as photo acrylic. The organic encapsulation layer **144** is disposed in the active area AA so as to expose the non-active area NA. If the organic encapsulation layer **144** is formed through an inkjet method, a plurality of dams **106** is formed so as to be disposed parallel to each other between the non-active area NA and the active area AA and to surround the active area AA. The dams **106** serve to prevent the organic encapsulation layer **144** in a liquid state from invading the non-active area NA, in which a touch pad **170** and a display pad **180** are disposed, when the organic encapsulation layer **144** in the liquid state drops onto the active area AA. Each of the dams **106** is formed to have a single-layer or multi-layer structure. For example, each of the dams **106** is formed of the same material as at least one of the bank **128** or a spacer and is formed simultaneously therewith, and thus no additional mask process can be required and a cost increase can be prevented.

[0040] Touch-sensing lines **154** and touch-driving lines **152** are disposed on the second inorganic encapsulation layer **146** of the encapsulation unit **140**. A mutual capacitance C_m is formed between the touch-sensing lines **154** and the touch-driving lines **152**. The mutual capacitance C_m performs a charging operation using a touch driving pulse supplied to the touch-driving lines **152** and discharges the charge to the touch-sensing lines **154**, thereby serving as a touch sensor.

[0041] The organic light-emitting display device having the touch sensor displays an image through a plurality of sub-pixels, each including the light-emitting element **120**, during the display operation. In addition, during the touch operation, the organic light-emitting display device having the touch sensor senses the amount of change of the mutual capacitance C_m (the touch sensor) caused by a user touch, thereby sensing whether there is a touch and the touch position.

[0042] Each of the touch-driving lines **152** included in the touch sensor includes a plurality of first touch electrodes **152e** and first bridges **152b** to electrically connect the first touch electrodes **152e**.

[0043] The first touch electrodes **152e** are spaced apart from each other at regular intervals in the X-axis direction (the row direction), which is the first direction, on the second inorganic encapsulation layer **146**, which is the uppermost layer of the encapsulation unit **140**. Each of the first touch electrodes **152e** is electrically connected to an adjacent first touch electrode **152e** via a corresponding one of the first bridges **152b**.

[0044] The first bridges **152b** are disposed in the spaces between the first and second touch electrodes **152e** and **154e** and in the spaces between the first touch electrodes **152e** and the second bridges **154b** on the second inorganic encapsulation layer **146**, on which the first touch electrodes **152e** are also disposed. Further, since the first bridges **152b** are formed through the same mask process as the first touch electrodes **152e**, the first bridges **152b** are formed integrally with the first touch electrodes **152e** without separate contact holes. The first bridges **152b** are coplanar with the first touch electrodes **152e**, the second touch electrodes **154e** and the

second bridges **154b** and are formed of the same material. Thus, the touch sensor of the present invention is formed in a single-layer structure.

[0045] To this end, the first bridges **152b** are disposed so as to extend along the second touch electrodes **154e** and the second bridges **154b** in a convoluted form and are electrically connected to the first touch electrodes **152e** and the first bridges **152b**, which are adjacent thereto in the first direction.

[0046] Specifically, as shown in FIG. 4, the first touch electrodes **152e** disposed in the second row H2 are connected to each other via the first bridges **152b**, which extend in a convoluted form along the second touch electrodes **154e** and the second bridges **154b** that are disposed in the third row H3 to the n^{th} row Hn (e.g., H7), where n is a natural number greater than i and represents the last row of the touch sensor. The first touch electrodes **152e** disposed in the fourth row H4 are connected to each other via the first bridges **152b**, which extend in a convoluted form along the second touch electrodes **154e** and the second bridges **154b** that are disposed in the fifth row H5 to the n^{th} row Hn (e.g., H7). That is, the first touch electrodes **152e** disposed in the i^{th} row Hi (where i is a natural number) are connected to each other via the first bridges **152b**, which extend in a convoluted form along the second touch electrodes **154e** and the second bridges **154b** that are disposed in the $i+1^{\text{th}}$ row Hi+1 to the n^{th} row Hn.

[0047] Each of the touch-sensing lines **154** includes a plurality of second touch electrodes **154e** and second bridges **154b** to electrically connect the second touch electrodes **154e**.

[0048] The second touch electrodes **154e** are spaced apart from each other at regular intervals in the Y-axis direction (the column direction), which is the second direction, on the second inorganic encapsulation layer **146**, on which the first touch electrodes **152e** and the first bridges **152b** are also disposed. Each of the second touch electrodes **154e** is electrically connected to an adjacent second touch electrode **154e** via a corresponding one of the second bridges **154b**.

[0049] The second bridges **154b** are electrically connected to the second touch electrodes **154e** and the second bridges **154b** that are adjacent thereto in the second direction on the second inorganic encapsulation layer **146**, on which the first touch electrodes **152e**, the first bridges **152b** and the second touch electrodes **154e** are also disposed. Since the second bridges **154b** are formed through the same mask process as the second touch electrodes **154e**, the second bridges **154b** are formed integrally with the second touch electrodes **154e** without separate contact holes. The second bridges **154b** are disposed between the first bridges **152b**, and the first bridges **152b** are disposed to be symmetrical in the lateral direction with respect to the second bridges **154b**.

[0050] As described above, according to the present invention, the first and second touch electrodes **152e** and **154e** and the first and second bridges **152b** and **154b** are coplanar with each other, e.g., are disposed on the uppermost layer (the second inorganic encapsulation layer **146**) of the encapsulation unit **140**, and are formed of the same material as each other, thereby simplifying the structure and the processing thereof. For example, the first and second touch electrodes **152e** and **154e** and the first and second bridges **152b** and **154b** are implemented as transparent conductive

films, such as ITO, IZO, IGZO or silver nanowire (AgNW), so that light generated from the light-emitting element is emitted outside.

[0051] A display pad **180** and a touch pad **170**, which are connected to signal lines for driving the driving thin-film transistor **130** and the light-emitting element **120**, are disposed in the non-active area NA. The display pad **180** and the touch pad **170** can be disposed in the non-active area NA located on at least one of one side or the opposite side of the substrate **111**, or can be disposed in different non-active areas NA from each other. The structures of the touch pad **170** and the display pad **180** are not limited to the structures shown in FIG. 1, but can be variously changed depending on the design choices made for the display device.

[0052] The touch pad **170** and the display pad **180** are disposed on at least one insulating film of the buffer layer **112**, the interlayer insulating film **114** or the planarization layer **118**, which is disposed between the substrate **111** and the encapsulation unit **144**. The touch pad **170** is formed so as to be exposed together with a routing line **160** by the touch protective film **158**, and is thus connected to a signal transmission film, on which a touch-driving unit is installed. The touch protective film **158** is formed to cover the touch-sensing lines **154** and the touch-driving lines **152**, thus preventing the touch-sensing lines **154** and the touch-driving lines **152** from corroding due to external moisture or the like. The touch protective film **158** is formed in a film or thin-film configuration using an organic insulating material such as epoxy or acrylic, or is formed of an inorganic insulating material such as SiNx or SiOx.

[0053] The touch pad **170** is formed of the same material as the first and second touch electrodes **152e** and **154e**, the first and second bridges **152b** and **154b** and the routing line **160**.

[0054] The touch pad **170** is connected to the routing line **160**, which is disposed on the lateral surface of the encapsulation unit **140** via a lower connection electrode **182** and first and second upper connection electrodes **172** and **174**.

[0055] The lower connection electrode **182** is disposed on the gate insulating film **102** in the same pattern as the gate insulating film **102**. This lower connection electrode **182** is formed together with the gate electrode **132** and is formed of the same material.

[0056] The first upper connection electrode **172** electrically connects the lower connection electrode **182** and the routing line **160** to each other. The first upper connection electrode **172** is connected to the lower connection electrode **182**, which is exposed through a first connection contact hole **184a** that penetrates the interlayer insulating film **114**. The first upper connection electrode **172** is exposed through the routing contact hole **150**, which penetrates the crack prevention layer **188**, and is connected to the routing line **160**. The first upper connection electrode **172** is formed together with the source and drain electrodes **136** and **138** and is formed of the same material as the source and drain electrodes **136** and **138**.

[0057] The second upper connection electrode **174** electrically connects the lower connection electrode **182** and the touch pad **170** to each other. The second upper connection electrode **174** is electrically connected to the lower connection electrode **182**, which is exposed through a second connection contact hole **184b**, which penetrates the interlayer insulating film **114**. The second upper connection electrode **174** is exposed through the pad contact hole **176**,

which penetrates the crack prevention layer **188**, and is electrically connected to the touch pad **170**. The second upper connection electrode **174** is formed together with the source and drain electrodes **136** and **138** and is formed of the same material as the source and drain electrodes **136** and **138**.

[0058] The non-active area NA, in which the touch pad **170** and the display pad **180** are disposed, includes a bending area BA, in which the substrate **111** is bendable or foldable. The bending area BA corresponds to the area that is bent in order to place the non-display area such as the touch pad **170** and the display pad **180** on the rear surface of the active area AA. As shown in FIG. 2, this bending area BA is disposed within the upper side of the non-active area NA, which corresponds to a region between each of the touch pad **170** and the display pad **180** and the active area AA. Alternatively, the bending area BA can be disposed within at least one of the upper side, the lower side, the left side or the right side of the non-active area NA. Accordingly, the area occupied by the active area AA is maximized and the area corresponding to the non-active area NA is minimized on the entire screen of the display device.

[0059] As shown in FIG. 2, the connection electrodes **182**, **172** and **174** connecting the routing line **160** and the touch pad **170** to each other are disposed in the bending area BA across the bending area BA. As shown in FIG. 3, the crack prevention layer **188** is disposed in the bending area BA so that the bending area BA is easily bent.

[0060] The crack prevention layer **188** is formed of an organic insulating material having greater strain and higher impact resistance than the inorganic insulating film. For example, since the crack prevention layer **188** is formed together with at least one of the planarization layer **118** or the bank **128** (using the same mask), the crack prevention layer **188** is coplanar with at least one of the planarization layer **118** or the bank **128** and is formed of the same material. The crack prevention layer **188** formed of an organic insulating material has greater strain than the inorganic insulating material and thus alleviates bending stress caused by bending of the substrate **111**. Accordingly, the crack prevention layer **188** is capable of preventing cracking of the bending area BA, thus preventing cracks from spreading to the active area AA. In addition, the crack prevention layer **188** is capable of preventing bending stress from being applied to the thin films **112**, **102** and **114** formed of an inorganic insulating material and the lower connection electrode **182** and the upper connection electrodes **172** and **174** formed of a conductive material, which are disposed in the bending area BA. In particular, since the crack prevention layer **188** is disposed on the lower connection electrode **182** and on the first and second upper connection electrodes **172** and **174**, the lower connection electrode **182** and the first and second upper connection electrodes **172** and **174** are prevented from cracking in the bending area BA. As a result, the connection stability of the touch pad **170** and the routing line **160** via the lower connection electrode **182** and the upper connection electrodes **172** and **174** is improved.

[0061] As described above, according to the present invention, the first and second touch electrodes **152e** and **154e** and the first and second bridges **152b** and **154b** are formed to be disposed in the same plane, e.g., are disposed on the uppermost layer of the encapsulation unit **140**, and are formed of the same material as each other. Thus, according to the present invention, the first and second touch electrodes

152e and **154e** and the first and second bridges **152b** and **154b** are formed together through a single mask process, thereby simplifying the structure and the processing thereof. In addition, the conventional organic light-emitting display device is constructed such that a touch screen is attached to an organic light-emitting display device using an adhesive, whereas the organic light-emitting display device according to the present invention is constructed such that the touch electrodes **152e** and **154e** are disposed on the encapsulation unit **140** and thus does not require a separate adhesion process, thereby simplifying the processing thereof and reducing costs. In addition, the present invention is capable of preventing cracking using the crack prevention layer **188** disposed in the bending area BA. Accordingly, the present invention is capable of preventing cracks from spreading to the active area AA, thus preventing the occurrence of defects in the lines and malfunction of the device.

[0062] FIG. 5 is a cross-sectional view showing an organic light-emitting display device having a touch sensor according to a second embodiment of the present invention. FIG. 6 is a plan view showing the first and second touch electrodes shown in FIG. 5.

[0063] The organic light-emitting display device having the touch sensor shown in FIG. 5 has the same constituent components as the organic light-emitting display device having the touch sensor shown in FIG. 3, except that the first and second touch electrodes **152e** and **154e**, the first and second bridges **152b** and **154b**, the routing line **160** and the touch pad **170** include opaque conductive films **163**. Other modifications are possible. A detailed explanation of the same constituent components will be omitted or will be brief.

[0064] The first and second touch electrodes **152e** and **154e** include, as shown in FIGS. 5 and 6, transparent conductive films **161** and opaque conductive films **163** formed on or under the transparent conductive films **161** in a mesh configuration. The first and second bridges **152b** and **154b**, the routing line **160** and the touch pad **170** include transparent conductive films **161** and opaque conductive films **163** formed on or under the transparent conductive films **161** in the same pattern as the transparent conductive films **161**.

[0065] Alternatively, the first and second touch electrodes **152e** and **154e** can include only opaque conductive films **163** formed in a mesh configuration without transparent conductive films **161**, and the first and second bridges **152b** and **154b**, the routing line **160** and the touch pad **170** can include only opaque conductive films **163** without transparent conductive films **161**.

[0066] The transparent conductive films **161** are implemented as conductive films having excellent transparency, such as ITO, IZO, IGZO, or silver nanowire (AgNW).

[0067] The opaque conductive films **163** are implemented as at least one layered conductive film selected from among Ti, Al, Mo, MoTi, Cu, and Ta so as to have higher conductivity than the transparent conductive films **161**. For example, the opaque conductive films **163** are formed in a three-layered stacking structure such as Ti/Al/Ti, MoTi/Cu/MoTi or Ti/Al/Mo. The opaque conductive films **163** compensate for the resistance components of the transparent conductive films **161**, thereby improving the conductivity of the first and second touch electrodes **152e** and **154e**, the first and second bridges **152b** and **154b**, the routing line **160** and the touch pad **170**. In particular, the opaque conductive films

163 serve to reduce the line resistance of the first bridges **152b** extending in a convoluted form.

[0068] Although the opaque conductive films **163** of the touch electrodes **152e** and **154e** are illustrated in FIG. 6 as being formed in a mesh structure and having the same density as each other, the opaque conductive films **163** can be formed in a mesh structure so as to have different densities from each other in consideration of the line resistance of the first bridges **152b** so that the line resistance of each of the touch-driving lines **152** is uniform. For example, since the length of the first bridge **152b** disposed in the first row is the longest, the gap between the opaque conductive films **163** formed in a mesh structure is formed to be the smallest. On the other hand, since the length of the first bridge **152b** disposed in the last row is the shortest, the gap between the opaque conductive films **163** formed in a mesh structure is formed to be the largest. In addition, the frequency of the touch-driving signal supplied to the touch-driving lines **152** can be varied in consideration of the line resistance of the first bridges **152b**, which extend in a convoluted form. That is, considering the line resistance, which varies depending on the length of the first bridge **152b** of each of the touch-driving lines **152**, the frequency of the touch-driving signal supplied to the touch-driving lines **152** is varied in a multi-frequency driving manner.

[0069] FIG. 7A is a plan view showing the first and second touch electrodes including opaque conductive films shown in FIG. 6 in detail, and FIG. 7B is a plan view showing the first and second bridges shown in FIG. 6 in detail.

[0070] As shown in FIGS. 7A and 7B, the opaque conductive films **163** included in the first and second touch electrodes **152e** and **154e** and the opaque conductive films **163** included in the first and second bridges **152b** and **154b** are formed so as to overlap the bank **128** but not to overlap the red (R), green (G) and blue (B) light-emitting areas, thereby preventing deterioration in the aperture ratio and the transmittance attributable to the opaque conductive films **163**.

[0071] As described above, the organic light-emitting display device having the touch sensor according to the second embodiment of the present invention is constructed such that the first and second touch electrodes **152e** and **154e** and the first and second bridges **152b** and **154b** are formed to be disposed in the same plane and are formed of the same material as each other. Thus, according to the present invention, the first and second touch electrodes **152e** and **154e** and the first and second bridges **152b** and **154b** are formed together through a single mask process, thereby simplifying the structure and the processing thereof. In addition, the conventional organic light-emitting display device is constructed such that a touch screen is attached to an organic light-emitting display device using an adhesive, whereas the organic light-emitting display device according to the present invention is constructed such that the touch electrodes **152e** and **154e** are disposed on the encapsulation unit **140** and thus does not require a separate adhesion process, thereby simplifying the processing thereof and reducing costs. In addition, in the organic light-emitting display device having the touch sensor according to the present invention, since the first and second touch electrodes **152e** and **154e** and the first and second bridges **152b** and **154b** include the opaque conductive films **163**, it is possible

to lower the resistance values of the first and second touch electrodes **152e** and **154e** and the first and second bridges **152b** and **154b**.

[0072] FIG. 8 is a cross-sectional view showing an organic light-emitting display device having a touch sensor according to a third embodiment of the present invention.

[0073] The organic light-emitting display device having the touch sensor shown in FIG. 8 has the same constituent components as the organic light-emitting display device having the touch sensor shown in FIG. 3, except that a color filter array is further included. Other variations are possible. A detailed explanation of the same constituent components will be omitted or will be brief.

[0074] Referring to FIG. 8, the color filter array includes color filters **192** and black matrixes **194** disposed on the second inorganic encapsulation layer **146** of the encapsulation unit **140**. The color filters **192** are formed between each of the touch-sensing lines **154** and the touch-driving lines **152** and the encapsulation unit **140**. The spacing distance between each of the touch-sensing lines **154** and the touch-driving lines **152** and the light-emitting element **120** is increased by the color filters **192**. Thus, the capacity of a parasitic capacitor formed between each of the touch-sensing lines **154** and the touch-driving lines **152** and the light-emitting element **120** can be minimized, thus preventing each of the touch-sensing lines **154** and the touch-driving lines **152** and the light-emitting element **120** from mutually affecting each other due to the coupling therebetween. In addition, the color filters **192** are capable of preventing liquid chemical (developer, etchant or the like), which is used for the manufacture of the touch-sensing lines **154** and the touch-driving lines **152**, or external moisture from permeating the light-emitting stack **124**. Thus, the color filters **192** are capable of preventing damage to the light-emitting stack **124**, which is vulnerable to liquid chemical or moisture.

[0075] Each of the black matrixes **194** is disposed between adjacent color filters **192**. The black matrixes **194** serve to divide the sub-pixel areas from each other and to prevent optical interference and light leakage between the adjacent sub-pixel areas. The black matrixes **194** are formed of a black insulating material having high resistance, or are formed such that at least two of red (R), green (G) and blue (B) color filters **192** are stacked.

[0076] A color planarization layer **196**, which is formed of an organic insulating material, is disposed on the substrate **111**, on which the color filters **192** and the black matrixes **194** have been formed. The substrate **111**, on which the color filters **192** and the black matrixes **194** are formed, is flattened by the color planarization layer **196**.

[0077] It is illustrated by way of example in FIG. 8 that the touch electrodes **152e** and **154e** are disposed on the color filters **192**. Alternatively, as shown in FIG. 9, the color filters **192** can be disposed on the touch electrodes **152e** and **154e**. In this case, the touch electrodes **152e** and **154e** are disposed between the color filters **192** and the encapsulation unit **140**.

[0078] FIG. 10 is a cross-sectional view showing an organic light-emitting display device having a touch sensor according to a fourth embodiment of the present invention.

[0079] The organic light-emitting display device having the touch sensor shown in FIG. 10 has the same constituent components as the organic light-emitting display device having the touch sensor shown in FIG. 3, except that lateral protective films **148** are further included. Other variations

are possible. A detailed explanation of the same constituent components will be omitted or will be brief.

[0080] The lateral protective films **148** shown in FIG. 10 are formed to cover the lateral surfaces of the routing line **160** and the touch pad **170**, which are exposed to the outside, in order to prevent the exposure of the lateral surfaces of the routing line **160** and the touch pad **170**. The lateral protective films **148** can prevent an increase in resistance due to defective electrochemical corrosion, which may be caused by exposure of the lateral surfaces of the routing line **160** and the touch pad **170**. The lateral protective films **148** are formed together with the touch protective film **158** and are formed of the same material as the touch protective film **158**. For example, the lateral protective films **148** are formed in a film or thin-film configuration using an organic insulating material such as epoxy or acrylic, or are formed of an inorganic insulating material such as SiNx or SiOx.

[0081] The touch pad **170** is connected to the second upper connection electrode **174** via the pad contact hole **176** between the crack prevention layers **188**, and is connected to a signal transmission film in a region between the crack prevention layers **188** and the distal end of the substrate **111**. In this case, the flat surface of the touch pad **170** is exposed in the region where the touch pad **170** is connected to the signal transmission film, whereby an increase in unevenness of the surface of the touch pad **170** can be prevented and thus defective connection between the touch pad **170** and the signal transmission film can be prevented.

[0082] As described above, the organic light-emitting display device having the touch sensor according to the fourth embodiment of the present invention is constructed such that the first and second touch electrodes **152e** and **154e** and the first and second bridges **152b** and **154b** are formed to be disposed in the same plane and are formed of the same material as each other. Thus, according to the present invention, the first and second touch electrodes **152e** and **154e** and the first and second bridges **152b** and **154b** are formed together through a single mask process, thereby simplifying the structure and the processing thereof. In addition, the conventional organic light-emitting display device is constructed such that a touch screen is attached to an organic light-emitting display device using an adhesive, whereas the organic light-emitting display device according to the present invention is constructed such that the touch electrodes **152e** and **154e** are disposed on the encapsulation unit **140** and thus does not require a separate adhesion process, thereby simplifying the processing thereof and reducing costs. In addition, in the organic light-emitting display device having the touch sensor according to the present invention, it is possible to prevent an increase in unevenness of the surface of the touch pad **170** and to prevent defective electrochemical corrosion of the touch pad **170** and the routing line **160** using the lateral protective films **148**.

[0083] FIG. 11 is a plan view showing the organic light-emitting display device having the touch sensor according to the embodiment(s) of the present invention that is applied to a large-area product.

[0084] As shown in FIG. 11, in the case in which the organic light-emitting display device having the touch sensor is applied to a large-area product, touch areas TA1 and TA2, in each of which a plurality of touch sensors is disposed, can be arranged to be symmetrical in the lateral direction or in the vertical direction.

[0085] It is illustrated by way of example in FIG. 2 that the second bridges **154b** extend between the second touch electrodes **154e** in the second direction, which is the same as the direction in which the second touch electrodes **154e** extend, and that the first bridges **152b** extend in a convoluted form along the second touch electrodes **154e** and the second bridges **154b** and are connected to the routing line **160**. However, the structures of the first and second bridges **152b** and **154b** are not limited to the structures shown in FIG. 2. For example, as shown in FIG. 11, the first bridges **152b** can extend between the second bridges **154b** in the first direction and can be connected to the other first bridges **152b** and the first touch electrodes **152e**, which are adjacent thereto in the first direction, and the second bridges **154b** can extend in a convoluted form along the first touch electrodes **152e** and the first bridges **152b** and can be connected to the other second bridges **154b** and the second touch electrodes **154e**, which are adjacent thereto in the second direction.

[0086] In addition, FIG. 12A a plan view showing region A of FIG. 11 in detail, and FIGS. 12B and 12C are cross-sectional views taken along line II-II' in FIG. 12A.

[0087] As shown in FIG. 12A, at least one of the first and second bridges **152b** and **154b** can have therein a plurality of slits **153**. For example, among the first and second bridges **152b** and **154b**, the bridge extending in a convoluted form is formed to have therein a plurality of slits **153**. As shown in FIG. 12B, the slits are formed to penetrate the opaque conductive films **163** of each of the bridges **152b** and **154b**. Alternatively, as shown in FIG. 12C, the slits are formed to penetrate the transparent conductive films **161** and the opaque conductive films **163**. The bridges **152b** and **154b** having the slits **153** can be reduced in area compared to bridges having no slits. Thus, reflection of external light by the bridges **152b** and **154b** can be reduced, thus preventing deterioration in visibility.

[0088] FIG. 13 is a flowchart showing a method of manufacturing the organic light-emitting display device having a touch sensor according to one or more embodiments of the present invention. The manufacturing method will be described with reference to the organic light-emitting display device having a touch sensor shown in FIG. 3.

[0089] Referring to FIGS. 3 and 13, first, multiple mask processes are carried out to form the driving transistor **130**, the lower connection electrode **182**, the upper connection electrodes **172** and **174** and the organic light-emitting element **120** on the substrate **111**. Subsequently, the first inorganic encapsulation film **142** is formed on the substrate **111**, on which the organic light-emitting element **120** has been formed, through a deposition method, such as a chemical vapor deposition (CVD) method, a low-pressure chemical vapor deposition (LPCVD) method or a plasma-enhanced chemical vapor deposition (PECVD) method. Here, the first inorganic encapsulation film **142** is formed of SiO_x, SiN_x or SiON. Subsequently, a photosensitive or non-photosensitive first organic insulating material is coated on the substrate **111**, on which the inorganic encapsulation film **142** has been formed, in order to form the organic encapsulation film **144**. Here, the organic encapsulation film **144** is formed of an organic insulating material, such as PCL, acrylic resin, epoxy resin, polyimide, polyethylene or silicon oxycarbide (SiOC). Subsequently, the second inorganic encapsulation film **146** is deposited on the entire surface of the substrate **111**, on which the organic encapsulation film **144** has been formed. Subsequently, the first and second

inorganic encapsulation films **142** and **146** are patterned through a photolithography process and an etching process to expose the non-active area NA disposed on the opposite side of the dam **106** (step S1).

[0090] Subsequently, a transparent conductive film is deposited on the entire surface of the substrate **111**, on which the encapsulation unit **140** has been formed, and is then patterned through a photolithography process and an etching process to form the first and second touch electrodes **152e** and **154e**, the first and second bridges **152b** and **154b**, the routing line **160** and the touch pad **170** (step S1).

[0091] The first and second touch electrodes **152e** and **154e**, the first and second bridges **152b** and **154b**, the routing line **160** and the touch pad **170**, which are shown in FIG. 5, are formed in a manner such that the transparent conductive film **161** and the opaque conductive film **163** are sequentially deposited and are then patterned through photolithography and etching processes using slits or a diffraction mask.

[0092] Subsequently, an inorganic insulating material or an organic insulating material is coated on the entire surface of the substrate **111**, on which the first and second touch electrodes **152e** and **154e**, the first and second bridges **152b** and **154b**, the routing line **160** and the touch pad **170** have been formed, and is then patterned through a photolithography process to form the touch protective film **158** (step S2).

[0093] As such, according to the present invention, after the encapsulation unit **140** is formed, the touch electrodes **152e** and **154e** and the bridges **152b** and **154b** are formed through the single first mask process. Subsequently, the touch protective film **158** is formed through the second mask process. In this case, after the encapsulation unit **140** is formed, a mask process for forming a conventional touch insulating film and a mask process for forming the bridges may be omitted. Therefore, according to the present invention, it is possible to form the touch sensor and the touch protective film **158** through a reduced number of mask processes (e.g., reduction from the conventional four mask processes to the two mask processes of the present invention), thereby simplifying the processing thereof and reducing costs.

[0094] As is apparent from the above description, according to the organic light-emitting display device having a touch sensor in the embodiments of the present invention, since the first and second touch electrodes and the first and second bridges are disposed in the same plane, e.g., are disposed on the encapsulation unit, and are formed of the same material, it is possible to form the first and second touch electrodes and the first and second bridges together through a single mask process, thereby simplifying the structure and the processing thereof. In addition, since the touch electrodes are disposed on the encapsulation unit, a separate adhesion process is not required, thus simplifying the processing thereof and reducing costs.

[0095] It will be apparent to those skilled in the art that various modifications and variations can be made in the present invention without departing from the spirit or scope of the invention. Thus, it is intended that the present invention covers the modifications and variations of this invention provided they come within the scope of the appended claims and their equivalents.

What is claimed is:

1. An organic light-emitting display device comprising: a light-emitting element disposed on a substrate; an encapsulation unit disposed on the light-emitting element; and a touch sensor disposed on the encapsulation unit, wherein the touch sensor comprises: first touch electrodes arranged on the encapsulation unit in a first direction, the first touch electrodes being connected to each other via first bridges; and second touch electrodes arranged on the encapsulation unit in a second direction, the second touch electrodes being connected to each other via second bridges, and wherein the first and second bridges and the first and second touch electrodes are formed of a same material as each other in a same plane, and the first and second bridges and the first and second touch electrodes are disposed on an uppermost layer of the encapsulation unit.
2. The organic light-emitting display device according to claim 1, wherein the first bridges extend in a convoluted form along the second bridges and the second touch electrodes, and are connected to first bridges and first touch electrodes disposed adjacent thereto in the first direction, and wherein the second bridges are disposed between the first bridges, and are connected to second bridges and second touch electrodes disposed adjacent thereto in the second direction.
3. The organic light-emitting display device according to claim 1, wherein the first bridges are disposed between the second bridges, and are connected to first bridges and first touch electrodes disposed adjacent thereto in the first direction, and wherein the second bridges extend in a convoluted form along the first bridges and the first touch electrodes, and are connected to second bridges and second touch electrodes disposed adjacent thereto in the second direction.
4. The organic light-emitting display device according to claim 1, further comprising: a routing line connected to each of the first touch electrodes and the second touch electrodes, the routing line being disposed on a lateral surface of the encapsulation unit; and a touch pad connected to the routing line.
5. The organic light-emitting display device according to claim 4, wherein the first and second bridges, the first and second touch electrodes, the routing line and the touch pad are formed of a material selected from among ITO, IZO, IGZO, and silver nanowire (AgNW).
6. The organic light-emitting display device according to claim 4, wherein each of the first and second touch electrodes comprises: an opaque conductive film formed in a mesh structure; and a transparent conductive film disposed on or under the opaque conductive film, wherein each of the first and second bridges, the routing line and the touch pad comprises: an opaque conductive film; and a transparent conductive film disposed on or under the opaque conductive film in a same pattern as the opaque conductive film, wherein the transparent conductive film is formed of a material selected from among ITO, IZO, IGZO, and silver nanowire (AgNW), and wherein the opaque conductive film is formed of at least one material of Al, Ti, Cu, or Mo, and has a single-layer or multi-layer structure.
7. The organic light-emitting display device according to claim 6, wherein the opaque conductive film of each of the first and second touch electrodes and the first and second bridges is disposed at a position corresponding to a bank defining a light-emitting area of the light-emitting element.
8. The organic light-emitting display device according to claim 1, further comprising: color filters disposed on or under the touch sensor; and black matrixes disposed between the color filters.
9. The organic light-emitting display device according to claim 4, further comprising: a lateral protective film covering a lateral surface of the touch pad.
10. The organic light-emitting display device according to claim 9, further comprising: a touch protective film exposing the routing line and the touch pad, the touch protective film overlapping the touch sensor, wherein the lateral protective film and the touch protective film are formed of a same material.
11. The organic light-emitting display device according to claim 1, wherein at least one of the first bridges or the second bridges has therein a plurality of slits.
12. The organic light-emitting display device according to claim 4, wherein the substrate comprises a bending area and is formed of a flexible material.
13. The organic light-emitting display device according to claim 12, further comprising: a plurality of connection electrodes disposed in the bending area to connect the routing line and the touch pad to each other; and a crack prevention layer disposed on the plurality of connection electrodes, the crack prevention layer overlapping the plurality of connection electrodes, and being formed of an organic insulating material.
14. The organic light-emitting display device according to claim 13, wherein the touch pad is connected to the plurality of connection electrodes exposed through a pad contact hole penetrating the crack prevention layer.
15. The organic light-emitting display device according to claim 1, wherein the first and second directions are substantially perpendicular to each other.

* * * * *

专利名称(译)	具有触摸传感器的有机发光显示装置		
公开(公告)号	US20190326361A1	公开(公告)日	2019-10-24
申请号	US16/387840	申请日	2019-04-18
[标]申请(专利权)人(译)	乐金显示有限公司		
申请(专利权)人(译)	LG DISPLAY CO. , LTD.		
当前申请(专利权)人(译)	LG DISPLAY CO. , LTD.		
[标]发明人	JUNG JI HYUN LEE DEUK SU AN SU CHANG LEE JAE GYUN		
发明人	GWON, HYANG-MYOUNG JUNG, JI-HYUN LEE, DEUK-SU AN, SU-CHANG LEE, JAE-GYUN RHE, RU-DA LEE, YANG-SIK		
IPC分类号	H01L27/32 H01L51/52 H01L51/00 G06F3/044		
CPC分类号	H01L51/0097 H01L27/322 H01L51/5253 H01L2251/5338 G06F3/044 H01L51/5284 H01L27/3276 H01L27/323 G06F3/041 H01L2227/323 G06F3/0412 G06F3/04164 G06F3/0446 G06F2203/04111		
优先权	1020180044949 2018-04-18 KR		
外部链接	Espacenet USPTO		

摘要(译)

讨论了具有触摸传感器的有机发光显示装置。有机发光显示装置包括形成单层结构并且设置在设置在发光元件上的封装单元上的触摸传感器。包括在具有单层结构的触摸传感器中的第一桥和第二桥以及第一触摸电极和第二触摸电极由彼此相同的材料在同一平面内(例如,在封装单元的最上层上)形成,从而简化了结构并降低成本。

